

flos collection



bejot:



**Tomasz
Augustyniak**

en:

Designer and interior architect, graduate of the Academy of Fine Arts in Poznań. Author of numerous collections of office and home furniture for major Polish brands. Winner of numerous design awards.

pl:

Projektant i architekt wnętrz, absolwent Akademii Sztuk Pięknych w Poznaniu. Autor wielu kolekcji mebli biurowych i domowych dla najważniejszych polskich marek. Laureat licznych nagród z dziedziny designu.

de:

Designer und Innenarchitekt, Absolvent der Akademie der Schönen Künste in Poznań. Autor zahlreicher Kollektionen von Büro- und Wohnmöbeln für große polnische Marken. Preisträger zahlreicher Designpreise.

The Flos furniture collection and multifunctional acoustic screens were designed with the idea of domesticating work and relaxation spaces.

be:cosy

be:comfortable

be:relaxed

be:homely

be:biophilic

bejot: of the world

:The starting point for me were two design directions, interdependent on each other:

form and ergonomics.

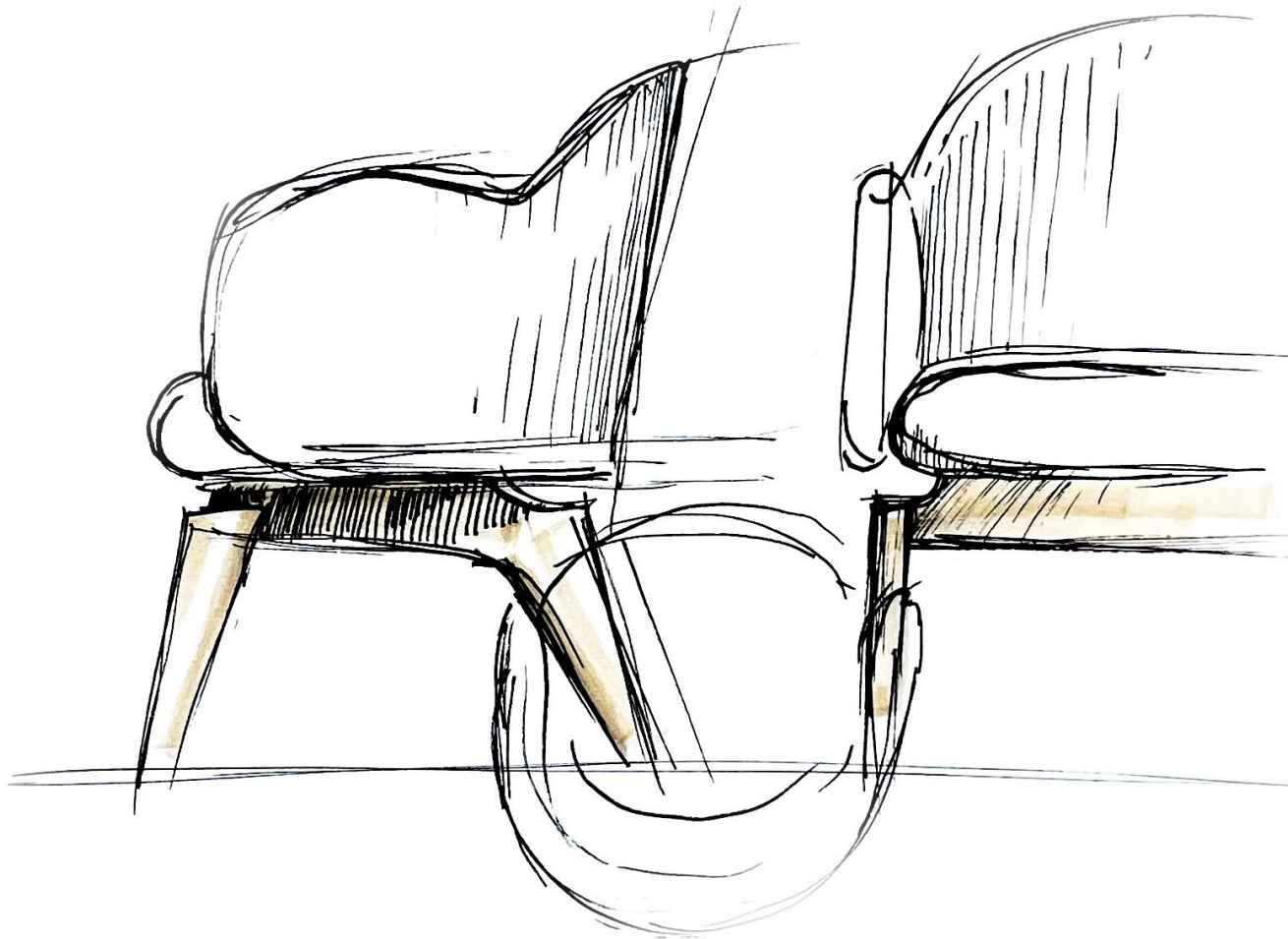

"I designed the Flos collection with domesticated work and leisure spaces in mind. My starting point was two design directions, interdependent: form and ergonomics.

The first - the search for a flowing shape line connecting all the elements of the collection, expressing peace, balance and harmony.

The second - to achieve maximum comfort in the furniture, while limiting the use of material.

In the acoustic walls, I was keen to enrich their functionality, so that both as individual pieces and as well as put together, they could perform additional 'meeting' and 'display' functions.

As a result, the fluid contour line of the furniture was inscribed into one of the sides of the walls and acoustic panels, opening up a wide range of possibilities for arrangement and composition".

**Tomasz Augustyniak
designer**

flos

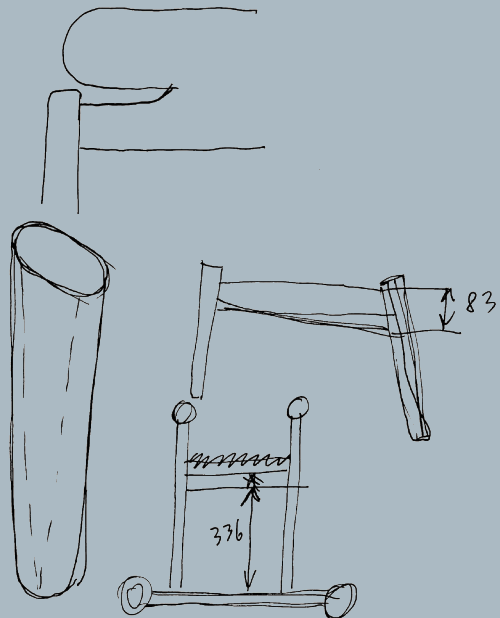
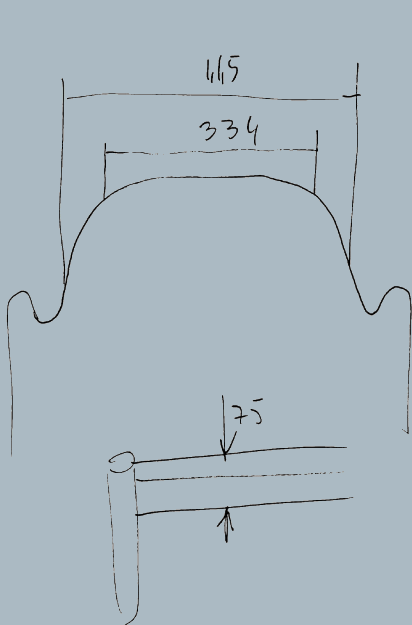
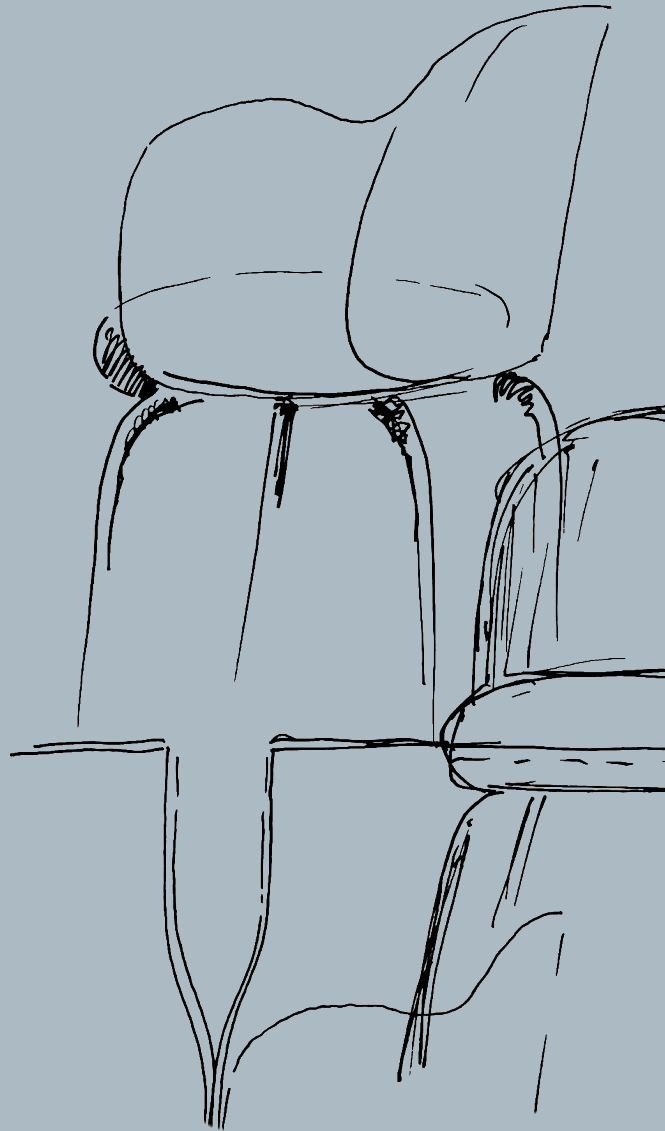
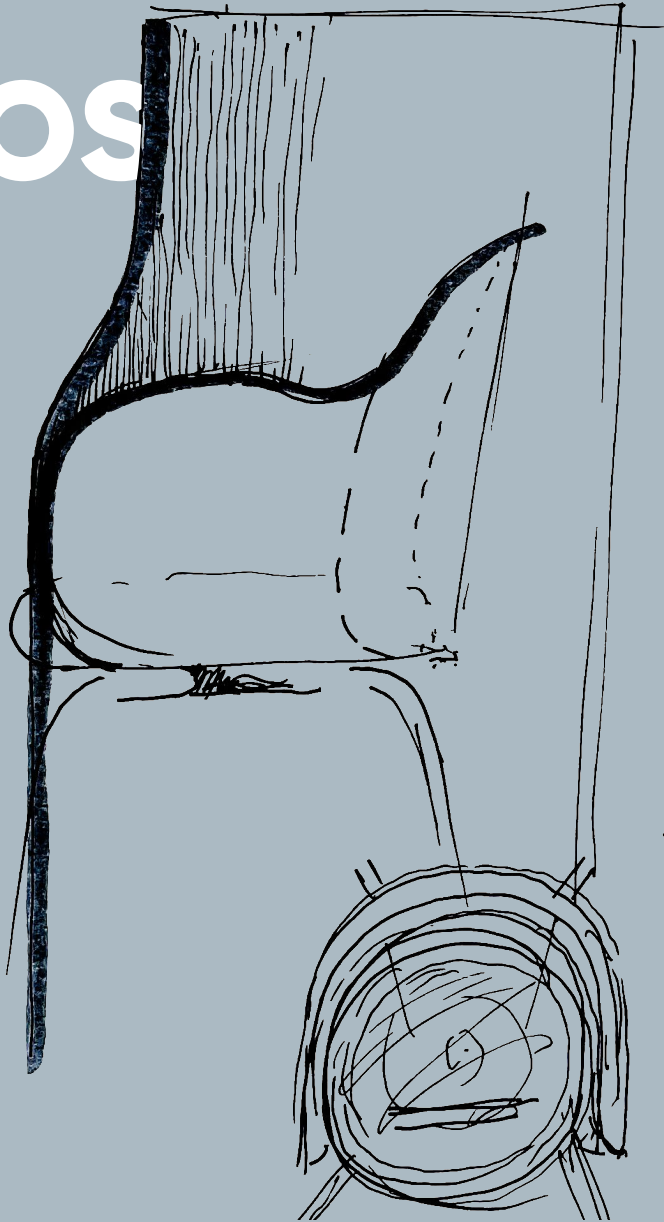



en:

Inspiration

Form and ergonomics are the determinants that have guided the process of creating Flos furniture from the very beginning.

While searching for the form, Tomasz Augustyniak focused on the flowing line of the shape, combining all the elements of the collection expressing peace, balance and harmony while achieving maximum comfort.

From the juxtaposition of these two concepts, and with a reduction in material use, our latest collection was created, containing diverse yet cohesive components linked by a distinctive wavy line based on floral motifs.

pl:

Inspiracja

Forma i ergonomia to wyznaczniki, które od samego początku kierowały proces tworzenia mebli Flos.

Podczas poszukiwania formy Tomasz Augustyniak skupił się na płynnej linii kształtu, łączącej wszystkie elementy kolekcji wyrażające spokój, równowagę i harmonię z jednoczesnym uzyskaniem maksymalnego komfortu. Z zestawienia tych dwóch koncepcji, a także przy ograniczeniu zużycia materiału powstała nasza najnowsza kolekcja zawierająca różnorodną, a jednocześnie spójną komponenty połączone charakterystyczną, falistą linią opartą o roślinne motywy.

de:

Inspiration

Form and Ergonomie sind die Determinanten, die den Entstehungsprozess der Flos-Möbel von Anfang an geleitet haben. Auf der Suche nach der Form konzentrierte sich Tomasz Augustyniak auf eine fließende Formlinie, die alle Elemente der Kollektion miteinander verbindet und Ruhe, Gleichgewicht und Harmonie bei maximalem Komfort zum Ausdruck bringt.

Aus der Gegenüberstellung dieser beiden Konzepte und mit einer Reduzierung des Materialeinsatzes entstand unsere neueste Kollektion, die aus verschiedenen, aber dennoch kohärenten Komponenten besteht, die durch eine charakteristische Wellenlinie mit floralen Motiven verbunden sind.



Wall FS SC8W + FS SC8TW + TBL-LAM
Upholstered with Alpa AP005
Metal finish RAL 9005 S
Bare **2TN**

Chair FS K 260
Upholstered with Alpa AP005
Metal finish RAL 9005 S

SNR DS 16L table
Metal finish RAL 9005 S
Laminated table top U999

flos acoustic walls

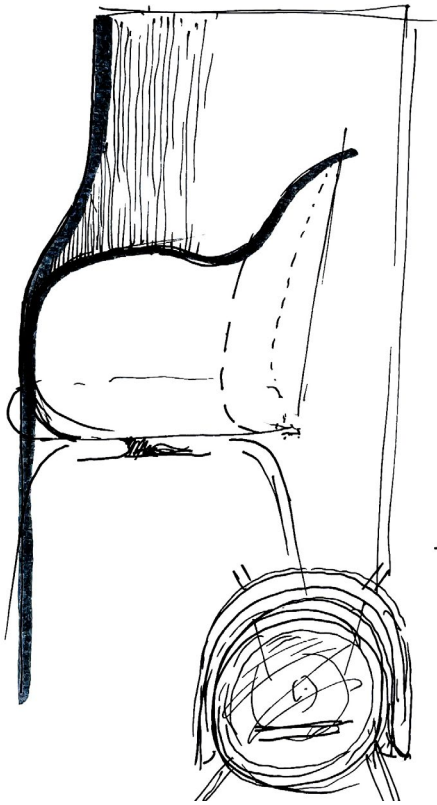

FS SC8TW

Upholstered with **Alpa AP005**

Metal finish **RAL 9005 S**

Bare **2TN**

en:

Acoustics

Flos furniture and multifunctional acoustic screens are designed with the idea of domesticating work and leisure spaces in mind. The free-standing acoustic screens fulfil three functions: practical (separation of space), acoustic (soundproofing) and aesthetic. The harmonious line of the form, which is related to the other elements of the collection, makes it possible to create coherent compositions, creating an intimate space.

pl:

Akustyka

Meble i wielofunkcyjne ekrany akustyczne Flos zostały zaprojektowane z myślą o idei udomowienia przestrzeni pracy i wypoczynku. Wolno stojące ekrany akustyczne pełnią trzy funkcje: praktyczną (oddzielenie przestrzeni), akustyczną (wyciszenie), a także estetyczną. Harmonijna linia formy nawiązująca do pozostałych elementów kolekcji pozwala tworzyć spójne układy kompozycyjne, kreując kameralną przestrzeń.

de:

Akustik

Die Flos-Möbel und Multifunktions-Akustikschirme wurden mit dem Gedanken entworfen, Arbeits- und Freizeiträume zu domestizieren. Die freistehenden Akustikschirme erfüllen drei Funktionen: praktische (Raumtrennung), akustische (Schalldämmung) und ästhetische. Die harmonische Linienführung der Form, die mit den anderen Elementen der Kollektion zusammenhängt, ermöglicht es, kohärente Kompositionen zu schaffen und einen intimen Raum zu gestalten.



FS SC8TW + TBH-HPL*
 Upholstered with **Alpa AP005**
 Metal finish **RAL 9005 S**
 Bare **2TN**

- * Tables TBH - HPL and TBH - LAM can only be used on 1 side of the wall
- * Stolik TBH - HPL oraz TBH - LAM można zastosować tylko z 1 strony ścianki
- * TBH - HPL und TBH - LAM Tische können nur auf 1 Seite der Wand verwendet werden

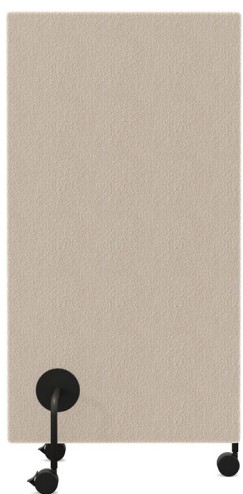

FS SC8W



FS SC8W + TBL-LAM



FS SC8W + TBL-LAM



FS SC8W + 2x TBL-LAM

flos free

free standing acoustic walls

en:

The connectors make it possible to connect two screens (in a straight line and at angles of 90° and 135°). The connectors can only be used for screens with a straight side (no wave-side connection possible).

pl:

Łączniki umożliwiają połączenie dwóch ekranów (w linii prostej oraz pod kątami: 90° i 135°). Łączniki można zastosować tylko do ekranów z prostym bokiem (brak możliwości połączenia od strony fali).

de:

Die Verbinder ermöglichen die Verbindung von zwei Schirmen (in einer geraden Linie und in Winkeln von 90° und 135°). Die Verbinder können nur für Schirme mit einer geraden Seite verwendet werden (keine Verbindung mit der Wellenseite möglich).

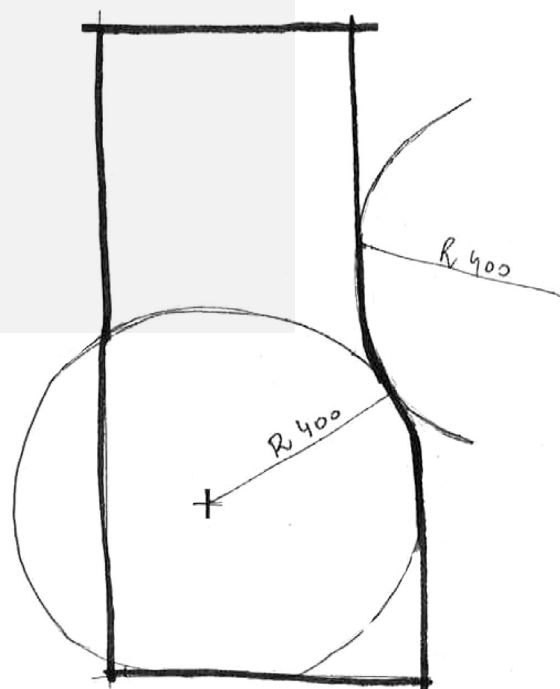

2x FS SC8
Upholstered with **Alpa AP005**
Metal finish **RAL 9005 S**







FS WS 60



FS WS 60 L



FS WS 60 R

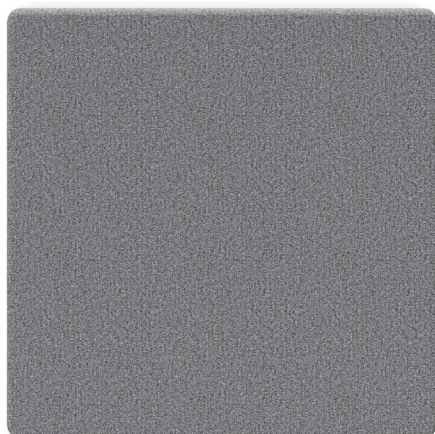

FS WS 120

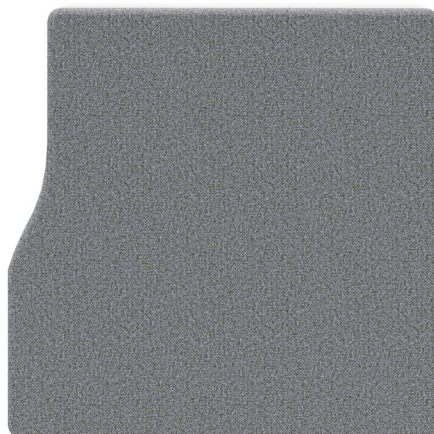

FS WS 120 L

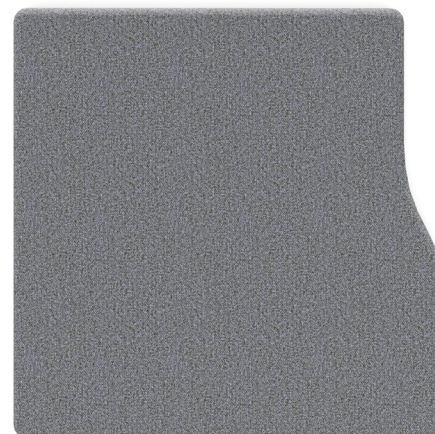

FS WS 120 R

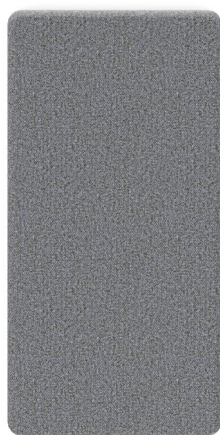

FS WRC 120



FS WRC120 L



FS WRC 120 R

en:

Acoustic walls

The distinctive, flowing contour line is inscribed into one of the sides of the panels and acoustic walls. The use of both individual screens and those set together creates coherent functional layouts and offers a wide range of design possibilities.

pl:

Ścianki akustyczne

Charakterystyczna, płynna linia konturu została wpisana w jeden z boków paneli i ścianek akustycznych. Wykorzystanie zarówno pojedynczych ekranów, jak i tych zestawionych razem, pozwala tworzyć spójne układy funkcjonalne i oferuje szerokie możliwości aranżacji.

de:

Akustische Wände

Die markante, fließende Konturlinie ist in eine der Seiten der Paneele und Akustikwände eingeschrieben. Die Verwendung sowohl einzelner als auch zusammengesetzter Stellwände schafft kohärente funktionale Layouts und bietet eine breite Palette von Gestaltungsmöglichkeiten.

flos wall

wall acoustic panels

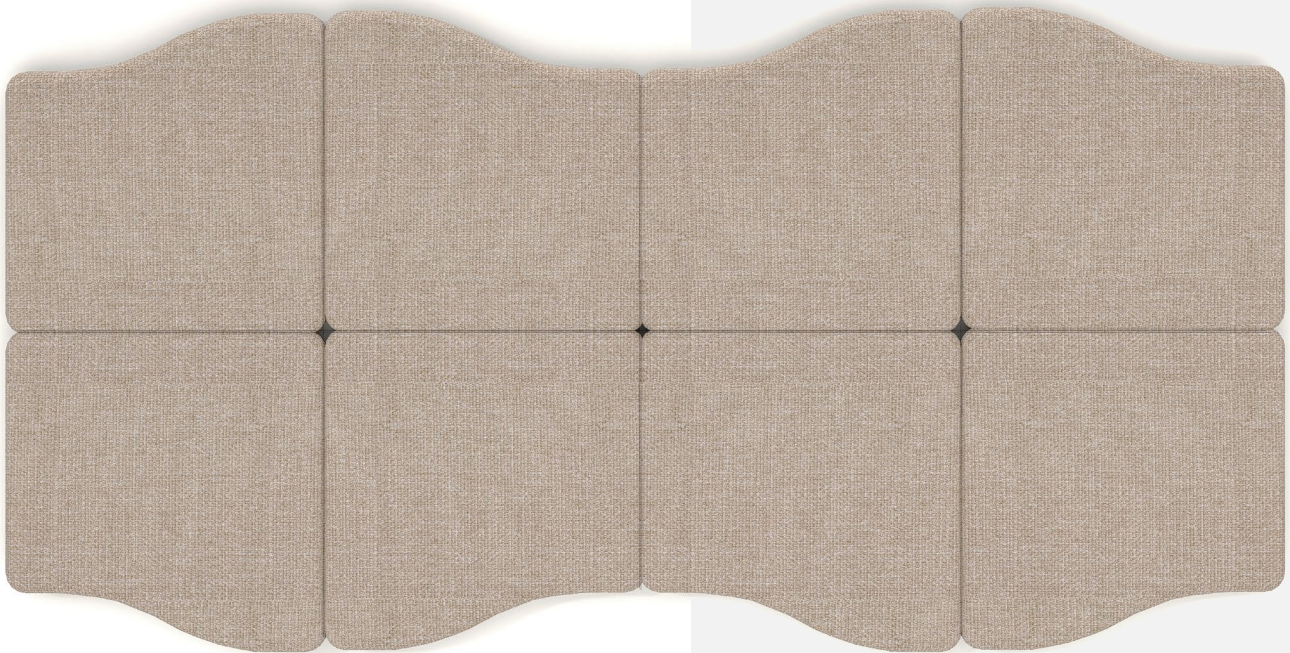
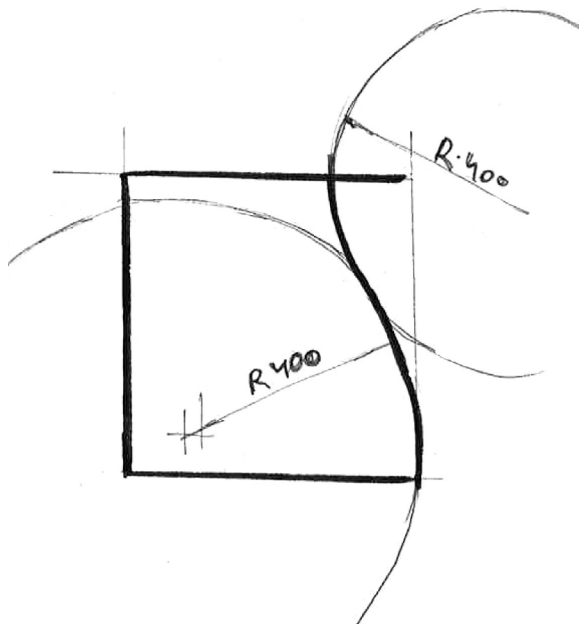

FS WS 60 L + FS WS 60 R



Wall panels FS WS 60 R
Upholstered with Synergy LDS38



be:creative

acoustic walls



FS WS 60 R

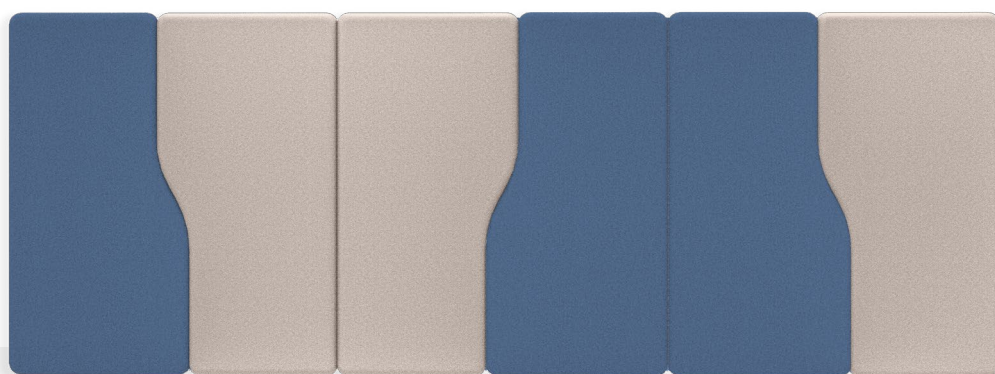

FS WRC 120 R + FS WRC 120 L



FS WS 60 R + FS WS 60

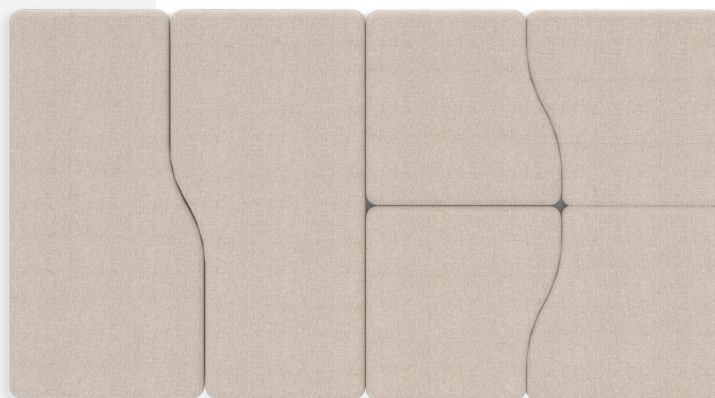

FS WRC 120 R + FS WS 60 L

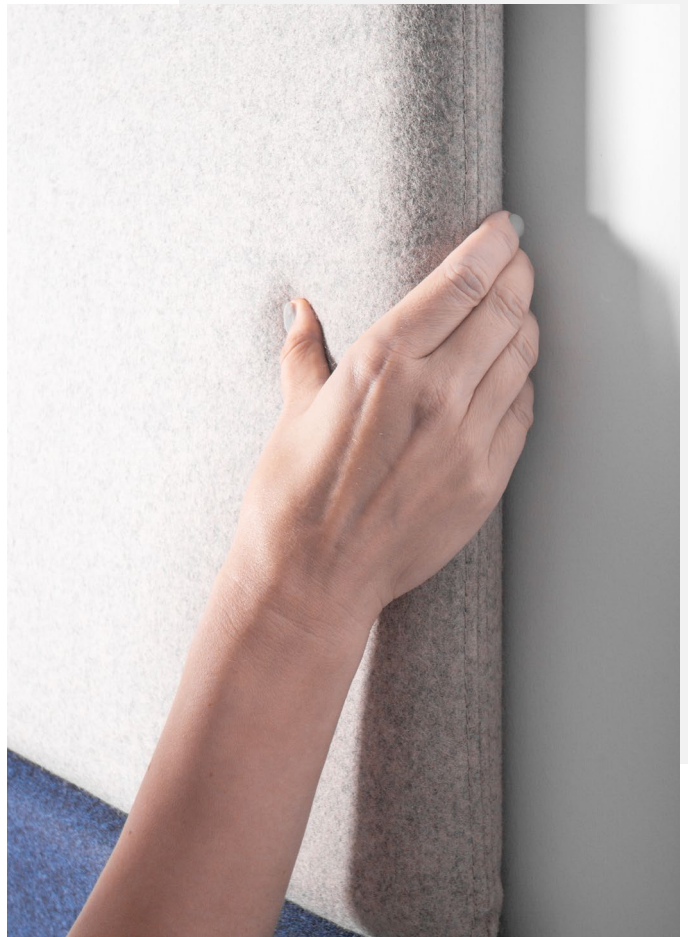

en:

Wall panels

Flos wall panels are thick and soft to reduce reverberation and lower noise levels. Velcro fastening allows for quick and easy installation, allowing the panels to be repeatedly joined and put together.

pl:

Panele ściienne

Panele ściienne Flos s grube i mikie, dziki czemu ograniczaj pogos i obnizaj poziom haasu. Mocowanie na rzepy pozwala na szybki i atwy monta, co umoliwia wielokrotne czenie i zestawianie paneli.

de:

Wandpaneelle

Flos Wandpaneelle sind dick und weich, um den Nachhall zu reduzieren und den Lrmpegel zu senken. Der Klettverschluss ermglicht eine schnelle und einfache Montage, so dass die Paneelle immer wieder zusammengesetzt und zusammengesetzt werden knnen.

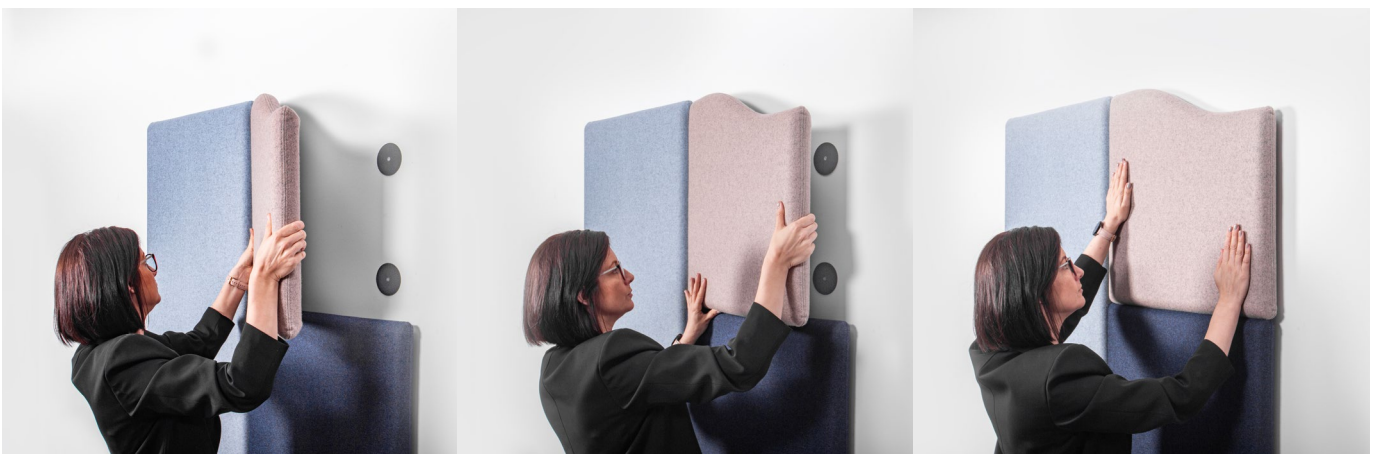

play with shapes!



Wall panels FS WRC 120 R + FS WRC 120 L
Upholstered with Synergy LDS05 and LDS23

Chair FS K 215
Upholstered with Alpa AP005
Metal finish RAL 9005 S



TB CONF3 table
Metal finish RAL 9005 S
Table: solid oak wood

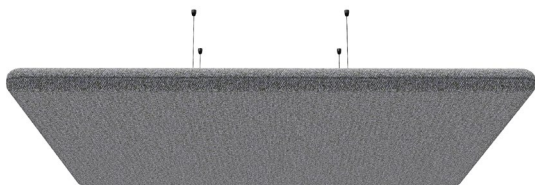

FS SS 120

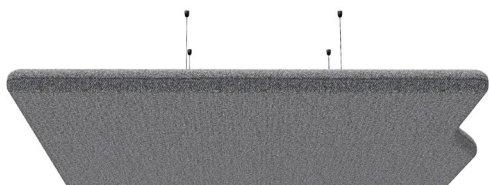
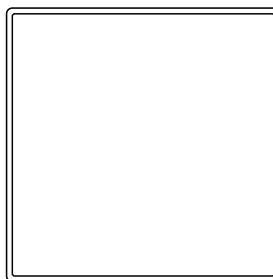

FS SS 120 R

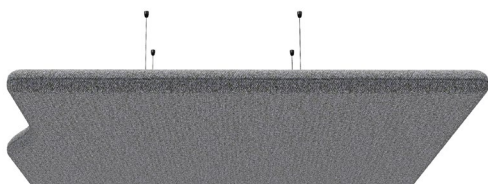
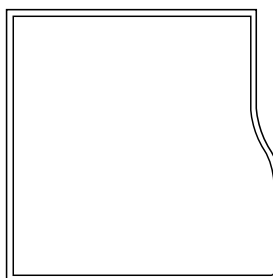

FS SS 120 L

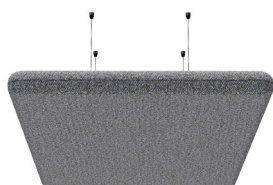
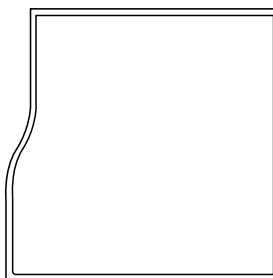

FS SRC 120

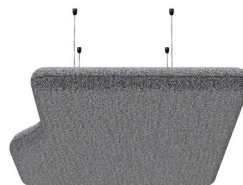
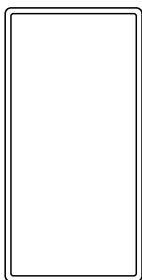

FS SRC 120 L

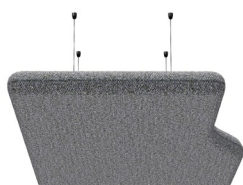
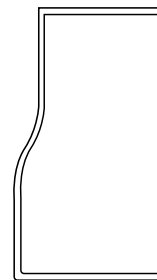

FS SRC 120 R

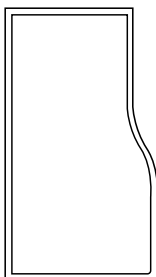

en:
Flos acoustic ceiling panels bring order and harmony to the interior through the use of flowing lines consistent throughout the collection.

pl:
Suftowe panele akustyczne Flos wprowadzają do wnętrza ład i harmonię dzięki zastosowaniu płynnej linii spójnej dla całej kolekcji.

de:
Die Akustikdecken von Flos bringen Ordnung und Harmonie in den Innenraum durch die Verwendung von fließenden Linien, die sich durch die gesamte Kollektion ziehen.

flos sky

ceiling acoustic panels



Chair FS K H
Upholstered with Ally AL 124
Metal finish RAL 9003 S

Spin SNR TB 18H table
Metal finish RAL 9003 S
Table top U708 ST9

Ceiling panels FS SS 120R + FS SRC 120 R
Upholstered with Synergy LDS05

Complete your collection





en:
Complete your Flos collection with wall, ceiling and freestanding acoustic panels.

pl:
Uzupełnij swoją kolekcję Flos o panele akustyczne ścienne, sufitowe i wolnostojące.

de:
Vervollständigen Sie Ihre Flos-Kollektion mit Wand-, Decken- und freistehenden Akustikpaneelen.

Flos free

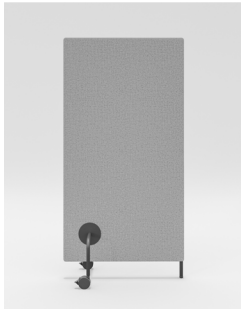

FS SC8W

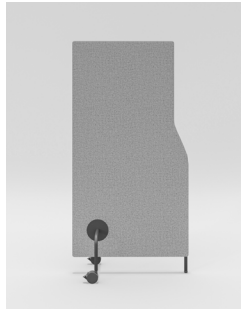

FS SC8TW



FS SC8



FS SC8T

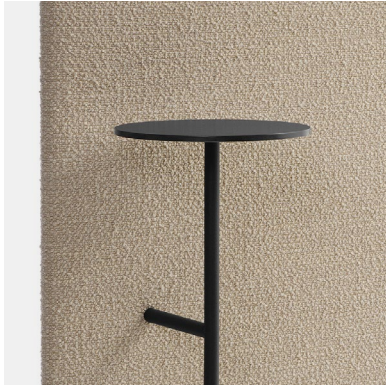

FS SC8W + 2x TBL-LAM



FS SC8W + TBL-LAM



en:

Additions

Optional installation of a table in two heights and an additional castor instead of a foot.

pl:

Dodatki

Możliwość opcjonalnego montażu stolika w dwóch wysokościach oraz dodatkowego kółka zamiast stopki.

de:

Zusätze

Optionaler Einbau eines Tisches in zwei Höhen und einer zusätzlichen Rolle anstelle eines Fußes.

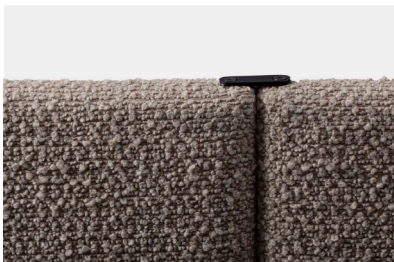

en:

Connectors

The connectors make it possible to connect two screens (in a straight line and at angles of 90° and 135°). The connectors can only be used for screens with a straight side.

pl:

Łączniki

Łączniki umożliwiające połączenie dwóch ekranów (w linii prostej oraz pod kątami: 90° i 135°). Łączniki można zastosować tylko do ekranów z prostym bokiem.

de:

Die Verbinder

Die Verbinder ermöglichen die Verbindung von zwei Schirmen (in einer geraden Linie und in Winkeln von 90° und 135°). Die Verbinder können nur für Schirme mit einer geraden Seite verwendet werden.

Technical data

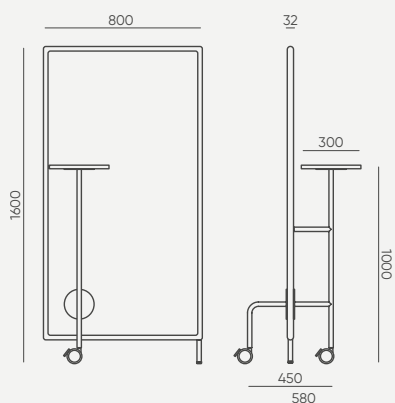

FS SC8W + TBH

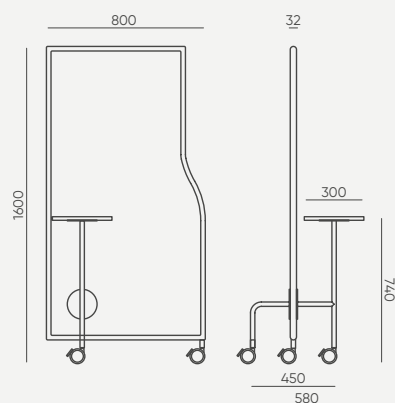

FS SC8TW + 3TN + TBL

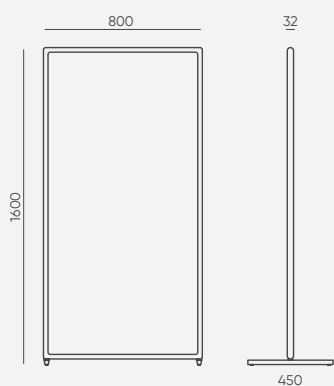

FS SC8

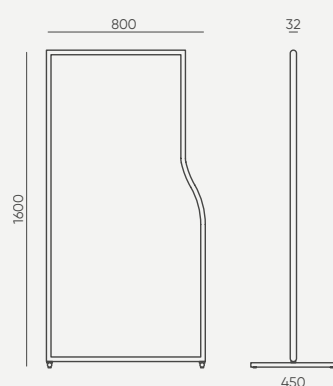

FS SC8T

* Tables TBH - HPL and TBH - LAM can only be used on 1 side of the wall

* Stolik TBH - HPL oraz TBH - LAM można zastosować tylko z 1 strony ścianki

* TBH - HPL und TBH - LAM Tische können nur auf 1 Seite der Wand verwendet werden

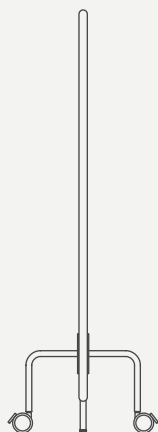

FS SC8W + 3TN

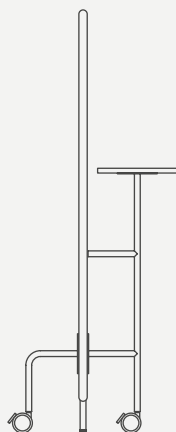

FS SC8W + TBH-LAM

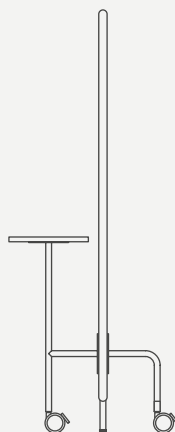

FS SC8W + TBL-LAM

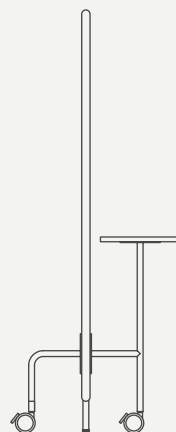

FS SC8W + TBL-LAM

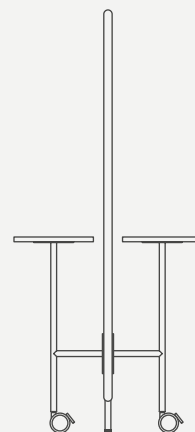

FS SC8W + 2X TBL-LAM

Flos wall



FS WS 60

FS WS 60 L

FS WS 60 R

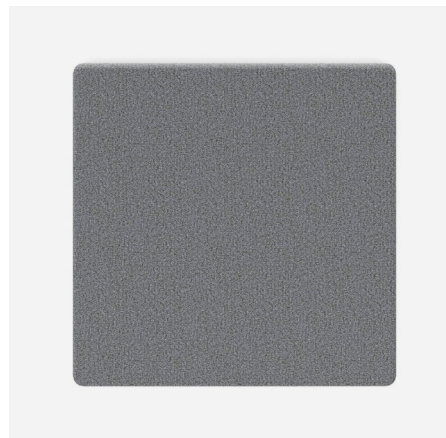

FS WS 120

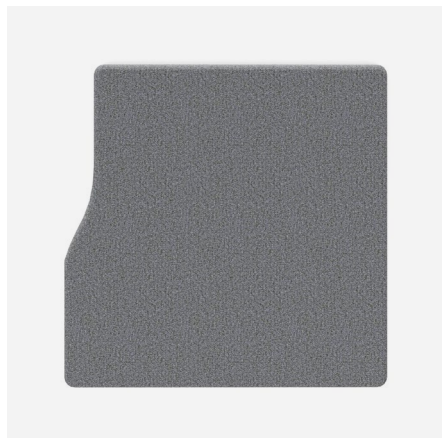

FS WS 120 L

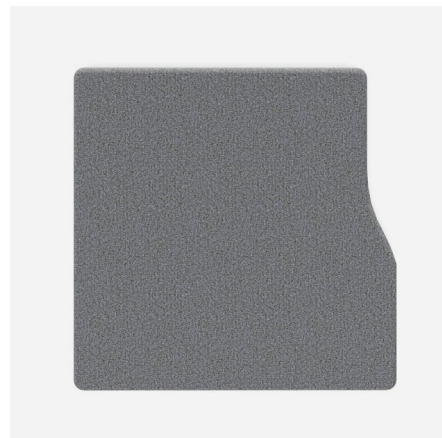

FS WS 120 R

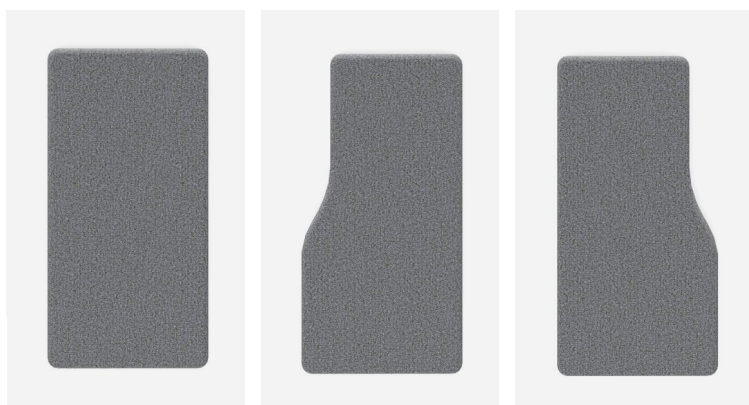

FS WRC 120

FS WRC 120 L

FS WRC 120 R

Flos sky

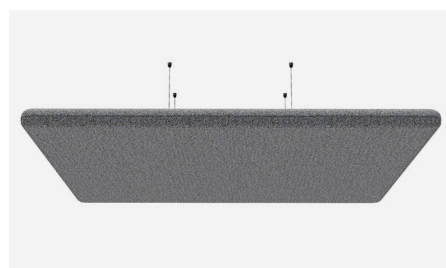

FS SS 120

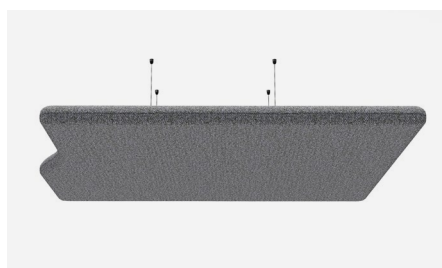

FS SS 120 L

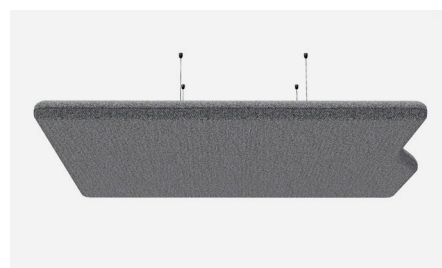

FS SS 120 R



FS SRC 120



FS SRC 120 L



FS SRC 120 R

Technical data

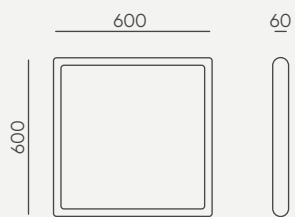

Flos WS 60

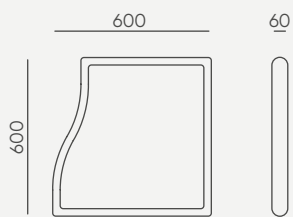

Flos WS 60 L

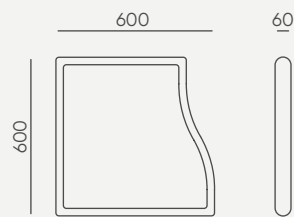

Flos WS 60 R

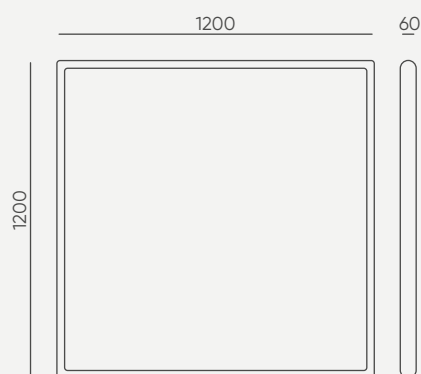

Flos Wall FS WS 120
Flos Sky FS SS 120

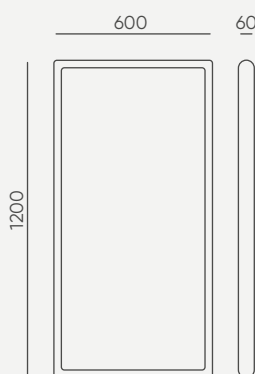

Flos Wall FS WRC 120
Flos Sky FS SRC 120

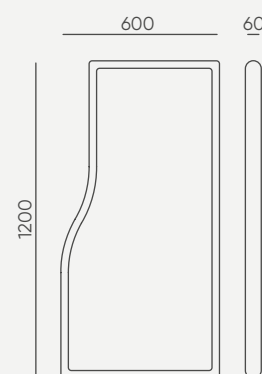

Flos Wall FS WRC 120 L
Flos Sky SRC 120 L

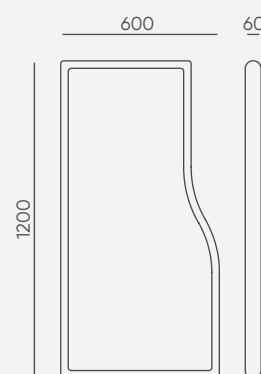

Flos Wall FS WRC 120 R
Flos Sky FS SRC 120 R

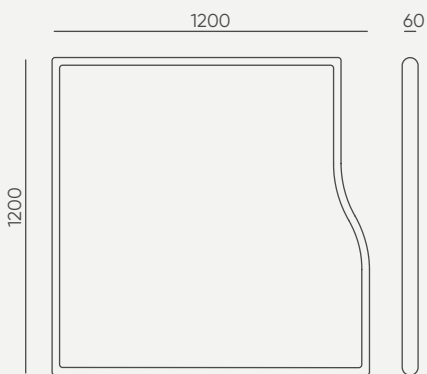

Flos Wall FS WS 120 R
Flos Sky FS SS 120 R

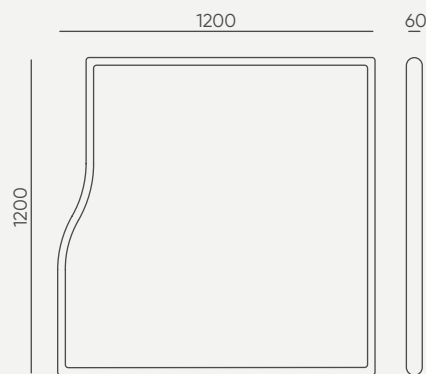

Flos Wall FS WS 120 L
Flos Sky FS SS 120 L

be:sustainable

product life-cycle management



en:

Quality, design and ergonomics are synonymous with Bejot's definition of sustainable development. We are socially responsible, honest and an environmentally friendly. **Flos collection** has been designed with sustainable solutions in mind, it is manufactured from certified materials, with optimized manufacturing processes and consistent control of production waste. Our goal is comfort in the office, which is reflected within our organization as well as in every piece of furniture we produce. We are helping our customers extend the life of our products by providing a 5-year warranty and after-warranty service, and we are introducing policy aimed at minimising waste at the end of the product life cycle.

pl:

Jakość, design i ergonomia to synonimy zrównoważonego rozwoju Bejot. Jesteśmy społecznie odpowiedzialni, działamy uczciwie i w sposób przyjazny dla środowiska. **Flos** został zaprojektowany z uwzględnieniem proekologicznych rozwiązań, jest produkowany z certyfikowanych materiałów, przy optymalizacji procesów produkcyjnych i konsekwentnym kontrolowaniu odpadów produkcyjnych. Naszym celem jest komfort w biurze, który przejawia się wewnątrz naszej organizacji, jak i w każdym wyprodukowanym przez nas meblu. Pomagamy klientom wydłużyć czas eksploatacji naszych produktów zapewniając 5 lat gwarancji i serwis pogwarancyjny, oraz wprowadzamy zasadę minimalizacji odpadów po zakończonym cyklu życia produktu.

de:

Qualität, Design und Ergonomie sind Synonyme der nachhaltigen Entwicklung, die von Bejot realisiert wird. Wir setzen auf soziale Verantwortung, handeln fair und umweltbewusst. Die **Flos Sitze** wurden unter Berücksichtigung pro-ökologischer Lösungen entwickelt. Sie werden aus zertifizierten Materialien, aus optimierten Produktionsprozessen und unter konsequenter Kontrolle der Produktionsabfälle hergestellt. Unser Ziel ist Komfort im Büro zu garantieren, der innerhalb unserer Organisation sowie in Form jedes von uns hergestellten Möbelstücks zu sehen sein wird. Wir helfen den Kunden die Lebensdauer unserer Produkte zu verlängern, dies dank einer 5-Jahres-Garantie sowie einem Nachgarantieservice. Wir realisieren auch das Prinzip der Abfallminimierung am Ende des Produktlebenszyklus.

Flos collection – ecology and recycling

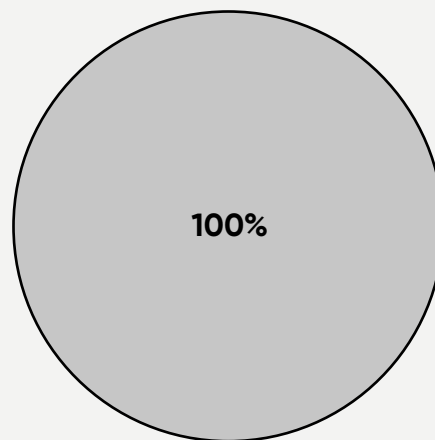
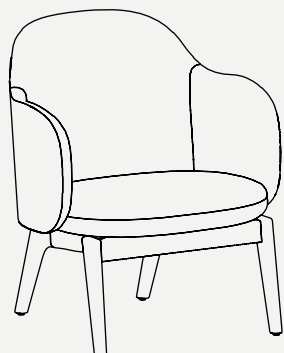

en:

We care about the environment

We use recyclable materials, e.g. in the sample Flos FSW F 720 chair presented above, we can reuse as much as 100% of the initial materials.

pl:

Dbamy o środowisko

Używamy materiałów podlegających recyklingowi, np. w powyższym przykładowym modelu krzesła Flos FSW F 720 możemy wykorzystać ponownie aż 100% mebla.

de:

Wir Schützen unsere Umwelt

Wir verwenden wiederverwertbare Materialien, wie z.B. bei den Flos FSW F 720 Sitzen oben, können wir bis zu 100 % des Möbelstücks wiederverwenden.



wood / drewno / Holz



33%



steel / stal / Stahl



42%



foam / pianka / Schaum



25%

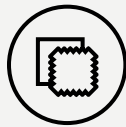

upholstery / tapicerka / Polster



8%



plastic / plastik / Plastik

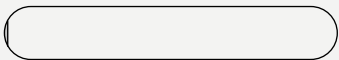

0,1 %

Bejot sp. z o.o.

ul. Wybickiego 2A, Manieczki, 63-112 Brodnica n. Poznań, POLAND

tel.: +48 (61) 281 22 25, e-mail: marketing@bejot.eu

www.bejot.eu